



# STR-1

The STR-1 transformer speed controllers are based on the principle of voltage control with auto-transformers. They are applicable to voltage-controllable motors (230 V, 50/60 Hz) to control in steps the rotational speed (of fans, pumps, etc.).

When choosing a controller it is important to know the maximum current intensity consumption on the taps. The indicated maximum current can be taken from each tap.

## Features

- < 230 Vac - 50/60 Hz
- < Enclosure: plastic (R-ABS, UL94-V0, grey RAL 7035) or sheet steel (RAL 7032, polyester powder coating)
- < IP54
- < Switch: 5 positions with off-position
- < Several voltage ranges possible
- < Indicator light
- < Current fuse
- < 230 Vac unregulated output
- < Ready mounted cable glands
- < Maximal ambient temperature: 35 °C

	Imax (A)	Fuse (A)
<b>STR-1-10L10</b>	1.0	(5*20 mm) 1.25
<b>STR-1-08L22</b>	0.8	(5*20 mm) 1.5
<b>STR-1-15L22</b>	1.5	2.0
<b>STR-1-22L22</b>	2.2	3.15
<b>STR-1-35L22</b>	3.5	5.0
<b>STR-1-50L22</b>	5.0	8.0
<b>STR-1-75L22</b>	7.5	10.0
<b>STR-1100L22</b>	10.0	(6*32 mm) 16.0
<b>STR-1130L22</b>	13.0	20.0
<b>STR-1160L20</b>	16.0	25.0
<b>STR-1200L20</b>	20.0	30.0

## Wiring diagram

STR-1-10L10

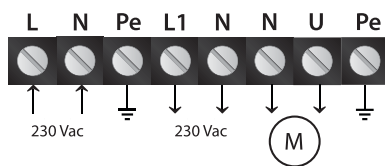

STR-1-08L22 < 22L22

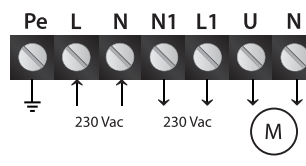

STR-1-35L22 < 200L20

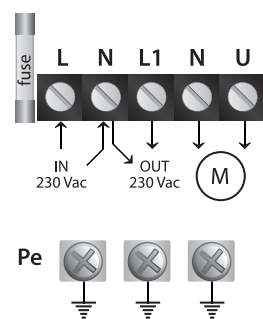

Type L22: by exchanging the fastonclip connectors on the transformer, one can adjust the order of switching and the voltage corresponding to each step of the switch.

## Dimensions & fixing

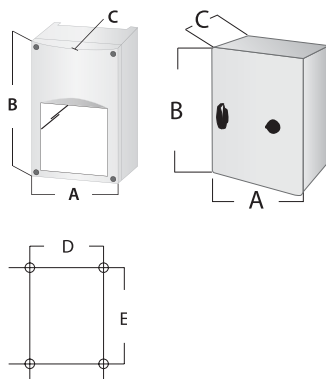

	A	B	C	D	E	net weight	gross weight	enclosure
<b>STR-1-10L10</b>	84	160	88	71	108	1.0 kg	1.1 kg	plastic
<b>STR-1-08L22</b>	115	205	100	98	140	1.6 kg	1.6 kg	plastic
<b>STR-1-15L22</b>	115	205	100	98	140	2.1 kg	2.1 kg	plastic
<b>STR-1-22L22</b>	115	205	100	98	140	4.3 kg	4.3 kg	plastic
<b>STR-1-35L22</b>	170	255	140	155	194	4.7 kg		plastic
<b>STR-1-50L22</b>	170	255	140	155	194	5.0 kg		plastic
<b>STR-1-75L22</b>	200	305	140	183	236	7.8 kg	7.9 kg	plastic
<b>STR-1100L22</b>	300	325	185	255	255	12.9 kg		steel
<b>STR-1130L22</b>	300	325	185	255	255	15.0 kg	15.1 kg	steel
<b>STR-1160L20</b>	300	425	235	255	355	18.4 kg		steel
<b>STR-1200L20</b>	300	430	235	255	355	21.0 kg		steel