



Compact heat recovery air handling units

KOMFORT Ultra EC S300

Air capacity – up to 300 m³/h

Heat recovery efficiency – up to 78 %

Application

- ❑ Air handling units for efficient supply and exhaust ventilation in flats, houses, cottages and other buildings.
- ❑ Heat recovery minimises ventilation heat losses.
- ❑ Control of air exchange for creating comfortable indoor microclimate.
- ❑ Compatible with round Ø125 mm air ducts.

Design

- ❑ The casing of **KOMFORT Ultra EC S300** is made of double-skinned aluzinc panels, internally filled with 20 mm mineral wool layer for heat and sound insulation.
- ❑ The casing of **KOMFORT Ultra EC S300 white** is made of double-skinned white painted metal panels, internally filled with 20 mm mineral wool layer for heat and sound insulation.
- ❑ The spigots are located at the top of the unit and are rubber sealed for airtight connection to the air ducts.
- ❑ The hinged panel of the casing ensures easy access to the unit internals for service works including cleaning, filter replacement, etc.

Fans

- ❑ The unit is equipped with high-efficient external rotor EC motors and centrifugal impellers with backward curved blades.
- ❑ EC motors have the best power consumption to air capacity ratio and meet the latest demands concerning energy saving and high-efficient ventilation.
- ❑ EC motors are featured with high performance, low noise level and totally controllable speed range.
- ❑ The impellers are dynamically balanced.

Heat recovery

- ❑ The **KOMFORT Ultra EC S300-H** unit is equipped with a plate cross-flow aluminium heat exchanger that recovers heat.
- ❑ The drain pan under the heat exchanger block of the **KOMFORT Ultra EC S300-H** is used for condensate collection and drainage.
- ❑ The **KOMFORT Ultra EC S300-E** unit is equipped with a plate enthalpy cross-flow heat exchanger made of polymerized cellulose that recovers heat and humidity.
- ❑ Due to humidity recovery the enthalpy heat exchanger produces no condensate.
- ❑ The air flows are fully separated within the heat exchangers. Odours and contaminants contained in the extract air are not transferred to the supply air flow.
- ❑ Heat recovery is based on heat and/or humidity transfer through the plates of the heat exchanger. In the cold season supply air is heated in the heat exchanger by transferring the heat energy of warm and humid extract air to the cold fresh air. Heat recovery minimizes heat losses, which reduces the cost of space heating. In summer the heat exchanger performs reverse and intake air is cooled in the heat exchanger by the cool extract air. This reduces load on air conditioners and saves electricity.
- ❑ The electronic frost protection system is used to prevent the heat exchanger freezing in cold seasons. In case of freezing danger communicated by the temperature sensor the supply fan is stopped to let

warm extract air warm up the heat exchanger. After that the supply fan is turned on and the unit reverts to the normal operation mode.

- ❑ In summer, when the indoor and outdoor temperature difference is small heat recovery is not reasonable. In this case the heat exchanger can be temporary replaced with a summer block for warm seasons (available separately).

Air filtration

- ❑ Two built-in cassette filters with filtration class G4 provide efficient supply and extract air filtration.
- ❑ Optionally, a cassette F8 filter can be installed to provide efficient supply air filtration.

Control and automation

- ❑ The **KOMFORT Ultra EC S300 S2** unit is equipped with the CDT E/0-10 speed controller that is included in the delivery.
- ❑ The **KOMFORT Ultra EC S300 S14** unit has an integrated control system with a wall-mounted control panel S14 with a LED indication.

The KOMFORT Ultra EC S300 S14 control panel functions:

- Turning the unit on/off
- Speed selection: Low, Medium or High
- Activation of the summer ventilation mode: The supply fan stops and the extract fan continues its operation with no heat recovery
- Alarm indication
- Filter maintenance indication

The KOMFORT Ultra EC S300 S14 unit is equipped with a USB connector (Type B) and can be connected to a PC for configuring the advanced settings in a special software:

- Fan speed adjustment from 0 to 100 %. Each speed is individually adjusted for the supply and the extract fans
- Operation control on feedback from the FS2 duct humidity sensor (available separately)
- Unit operation setting according to external control unit (available separately)
- Temperature setting for freeze protection system activation
- Control and operation adjustment of the filter maintenance timer
- Error code indication
- External control unit and humidity level control
- Software version upgrading

Mounting

- ❑ Mounting to floor, ceiling or wall with fixing brackets.
- ❑ While mounting provide free access to the service panel for filter replacement and servicing.
- ❑ The **KOMFORT Ultra EC S300-H** unit mounting position must provide condensate collection and drainage.

Technical data

Parameters	KOMFORT Ultra EC S300-H	KOMFORT Ultra EC S300-E
Unit voltage [V / 50-60 Hz]	1 ~ 230	
Power [W]	156	
Current [A]	1.17	
Maximum air capacity [m³/h]	300	
RPM	3200	
Sound pressure level at 3 m [dBA]	28-47	
Transported air temperature [°C]	from -25 up to +60	
Insulation	20 mm mineral wool	
Extract / supply filter	G4	
Replaceable filter*	G4 (F8 PM2.5 81 %)*	
Connected air duct diameter [mm]	125	
Heat recovery efficiency [%]	from 52 up to 78	from 50 up to 73
Humidity recovery efficiency [%]	-	from 25 up to 45
Heat exchanger type	cross-flow	
SEC class	A	
Heat exchanger material	aluminium	polymerized cellulose

*Replaceable filter kits are ordered separately.

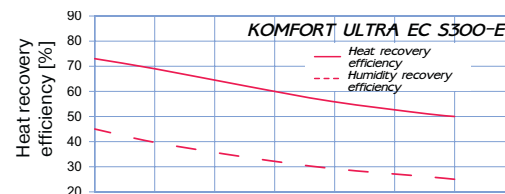
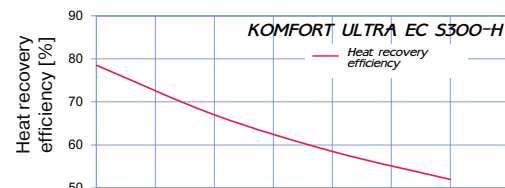
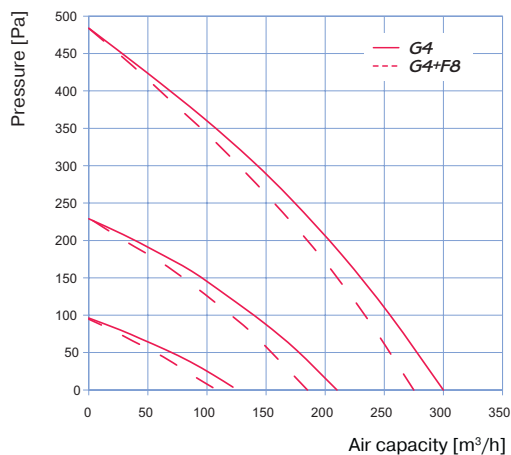

Overall dimensions, mm

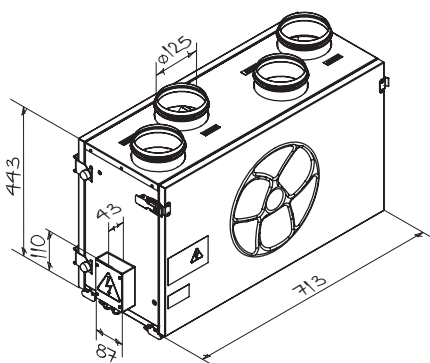

KOMFORT Ultra EC S300 S2

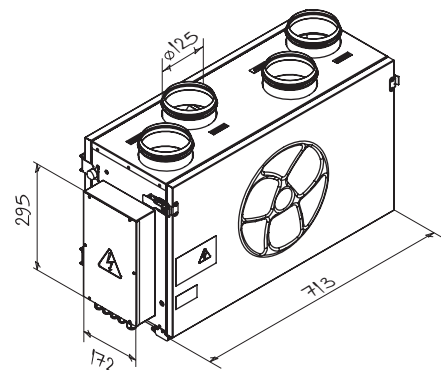

KOMFORT Ultra EC S300 S14